

Technical information

Resistance to soldering heat

■ Fuses are heat-sensitive components. The soldering conditions shown below are examples based on the use of our facilities. Sufficiently evaluate and examine your company's soldering conditions as they may vary depending on such factors as available facilities, solder type, solder quantity, board size, and board materials.

■ Board and solder used

Board: Glass epoxy, thickness 1.6 mm

Solder: Sn-3.0Ag-0.5Cu

■ Surface mount fuses: Reflow soldering
(11CT Type / 25CT Type / 36CFA / 36CT)

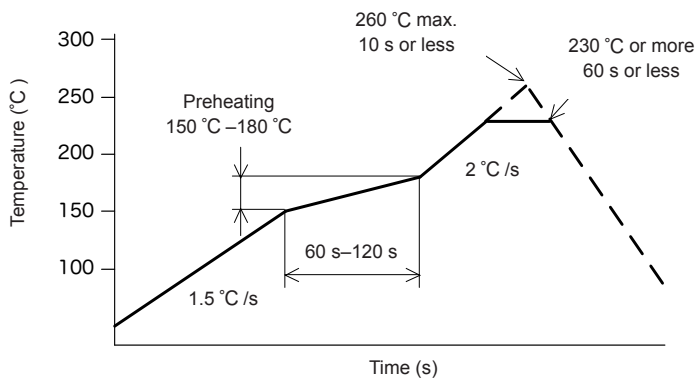

Soldering can be repeated a maximum of two times under these conditions.

※ For 36CFA fuses, please ensure that the height of the fillets is not more than one-third of the entire height of the fuse.

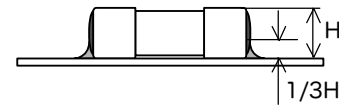

(MCF Type / MCF2)

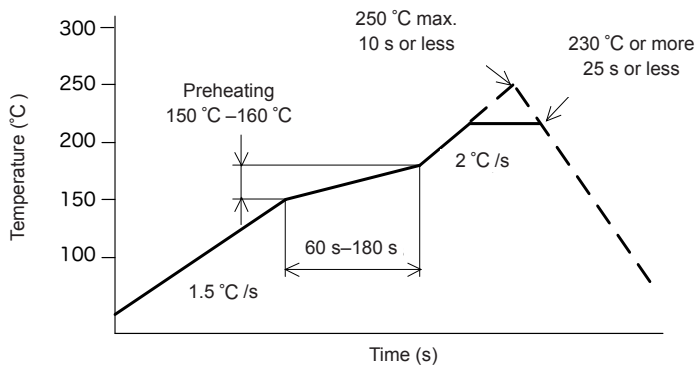

Soldering can be repeated a maximum of two times under these conditions.

※ For MCF Type, please ensure that the height of the fillets is not more than one-third of the entire height of the fuse.

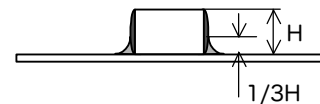

Note: Please contact your sales representative for information concerning the MCF3.

■ Sub-miniature fuses with leads (25RT Type)

• Wave soldering

Solder bath temp.: 260 °C or less

Duration: 10 s or less

• Hand soldering with soldering iron

Soldering iron tip temp.: 380 °C or less

Duration: 5 s or less

■ Pin terminal fuses (SM4 Type / SMC)

• Wave soldering

Solder bath temp.: 265 °C or less

Duration: 5 s or less

• Hand soldering with soldering iron

Soldering iron tip temp.: 350 °C or less

Duration: 2 s or less

■ Cartridge fuses with leads

• Wave soldering

Preheating temp.: 80 °C –140 °C
 Preheating time: 30 s–60 s
 Solder bath temp.: 260 °C or less
 Duration: 7 s or less

• Hand soldering with soldering iron

Soldering iron tip temp.: 380 °C or less
 Duration: 3 s or less

Lead wire diameter	Distance between the fuse body and the side to be soldered (L)
φ 0.5 mm φ 0.6 mm	5 mm or more
φ 0.8 mm φ 1.0 mm φ 1.2 mm	8 mm or more

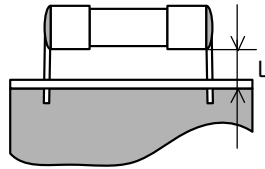

Lead wire diameter	Distance between the fuse body and the side to be soldered (L)
φ 0.5 mm φ 0.6 mm φ 0.8 mm φ 1.0 mm φ 1.2 mm	5 mm or more

Whiskers

The following tests are performed to ensure there is no whisker generation on the tin-plated parts of our products.

■ Temperature cycling test

After test samples are subjected to 500 cycles of temperature cycling as specified below, there shall be no whisker generation when observed using a microscope with a magnification of 40 times.

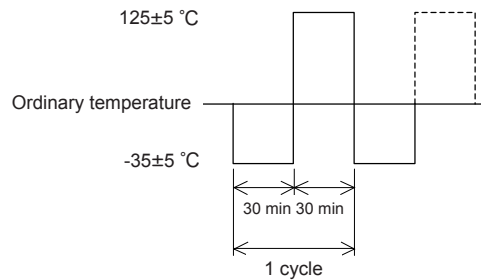

■ Constant temperature and humidity test

After test samples are left at a temperature of 85 °C and an RH of 85% for 500 h, there shall be no whisker generation when observed using a microscope with a magnification of 40 times.

Storage conditions

- Prerequisite: Products shall be packaged as delivered.
- Ambient temperature: -20 °C –+40 °C
- Ambient humidity: 85% RH or less
- Storage environment: Not exposed to corrosive gas or sea breeze.
Not exposed to direct sunlight.
Not subjected to loads which could cause deformation of the products.
- Storage period: Within one year from the date on the product packaging.

Packaging specifications

■ Surface mount fuses

Packaging method	Tape and reel packaging			Bag packaging	
Packaging code	R08B4	R12A4	R24D4	B	
Qty. packed	2000 pcs.	1000 pcs.	2000 pcs.	100 pcs.	
Dimensions (mm)	A	4	4	-	
	B	8	12		
	C	11.4	15.6		
	D	180	178		
Type name	11CF 11CT 32V11CF P11CF P11CT DC35V11CT DC35VP11CF DC35VP11CT DC86V11CT	MCF MCFA PMFA DC35VPMF MCF2 MCF3	25CF 25CT DC300V25CF P25CF P25CT DC35VP25CF DC35VP25CT	36CFA 36CT	Used for all fuse types

Tape and reel configuration / packing method (unit: mm)

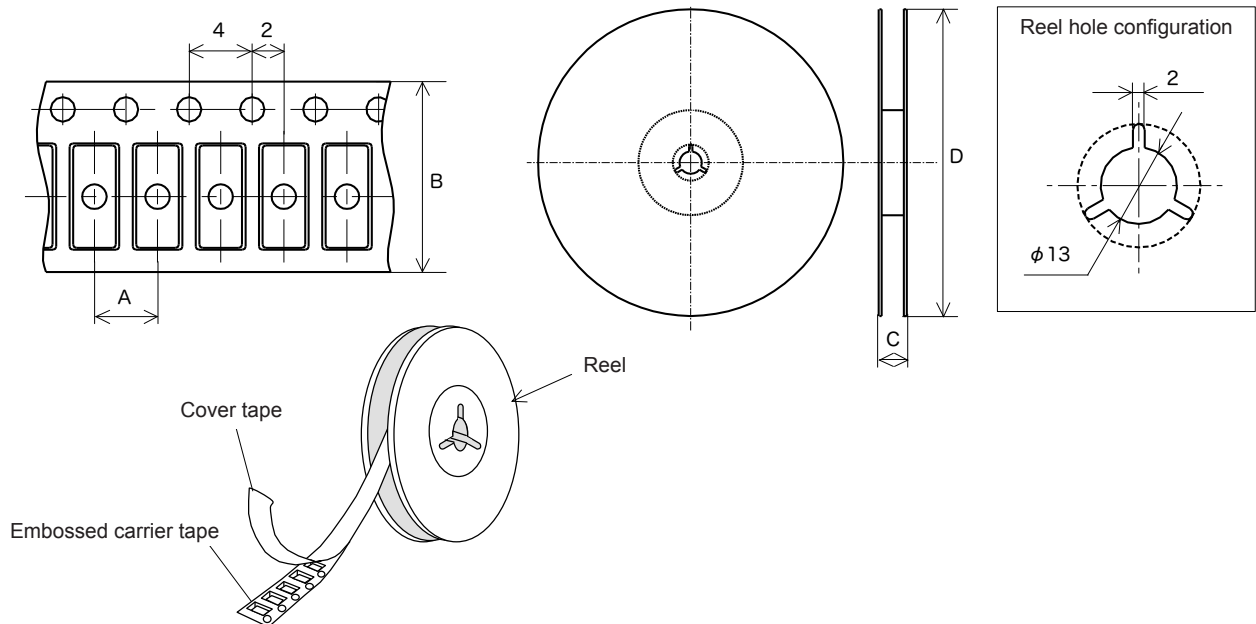

■ Bag packaging for sub-miniature fuses with leads

Type name	Forming specification	Standard total qty. per box	Packaging method
25RF	F002	2000 pcs.	100 pcs. × 20 bags
P25RF	F003		
DC35VP25RF	F006	1000 pcs.	100 pcs. × 10 bags
25RT	F007		
P25RT	F116		
DC35VP25RT	Without forming		

■ Bag / tape packaging for pin terminal fuses

Type name	Standard total qty. per box	Packaging method
SM4 PSM	1000 pcs.	100 pcs. × 10 bags
SMC	1000 pcs.	Tape packaging

Tape configuration / packing method for SMC (unit: mm)

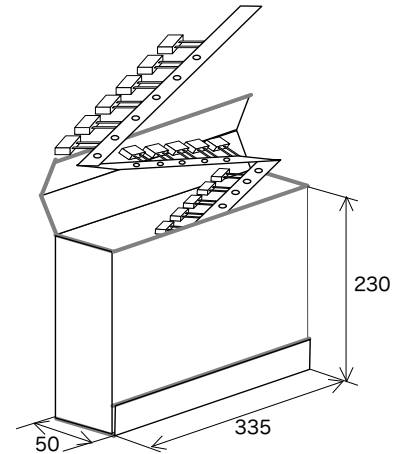
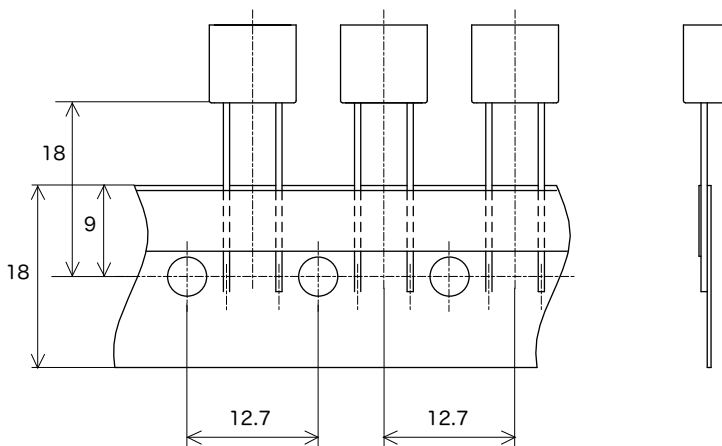

■ Bag packaging for cartridge fuses

Fuse dimensions (mm)	Standard total quantity per box		
	Cartridge type	Cartridge type with leads	
		Leads of ϕ 0.6mm or less	Leads of ϕ 0.8mm or greater
ϕ 4 × L9	2000 pcs. (1000 pcs. × 2 bags)	400 pcs. (100 pcs. × 4 bags)	400 pcs. (100 pcs. × 4 bags)
ϕ 4.6 × L14	1000 pcs. (1000 pcs. × 1 bag)	-	200 pcs. (100 pcs. × 2 bags)
ϕ 4.6 × L16	1000 pcs. (1000 pcs. × 1 bag)	400 pcs. (100 pcs. × 4 bags)	200 pcs. (100 pcs. × 2 bags)
ϕ 5.2 × L20	1000 pcs. (1000 pcs. × 1 bag)	400 pcs. (100 pcs. × 4 bags)	200 pcs. (100 pcs. × 2 bags)
ϕ 6.35 × L15.9	500 pcs. (500 pcs. × 1 bag)	-	200 pcs. (100 pcs. × 2 bags)
ϕ 6.35 × L20	-	-	100 pcs. (100 pcs. × 1 bag)
ϕ 6.35 × L25.4	500 pcs. (500 pcs. × 1 bag)	-	100 pcs. (100 pcs. × 1 bag)
ϕ 6.35 × L30	500 pcs. (500 pcs. × 1 bag)	-	100 pcs. (100 pcs. × 1 bag)
ϕ 6.35 × L31.8	400 pcs. (400 pcs. × 1 bag)	-	100 pcs. (100 pcs. × 1 bag)
ϕ 7.14 × L31.8	300 pcs. (300 pcs. × 1 bag)	-	-
ϕ 10.3 × L38.1	100 pcs. (100 pcs. × 1 bag)	-	50 pcs. (50 pcs. × 1 bag)

Please contact your sales representative for product packaging specifications not listed in this catalog.

Forming specifications

Please contact your sales representative for forming specifications not listed below and for questions regarding dimensional tolerances.

■ Cartridge fuses with leads (unit: mm)

The D dimensions in parentheses are for reference purposes only, and are not intended to infer any guaranteed values.

Fig. No.	Fuse dimensions	Lead wire diameter	Forming No.	Dimensions			
				A	B	C	D
* 1	$\phi 4 \times L9$	0.8	F451	5.2	10	9	(10)
	$\phi 4.6 \times L16$	0.8	F051	5.2	10	16	(17)
	$\phi 5.2 \times L20$	0.8	F013	5	9.5	20	(21)
		1.0	F057	5	8.6	20	(21.4)
	$\phi 6.35 \times L30$	1.0	F916	5	9.7	30	(32.2)
	$\phi 6.35 \times L31.8$	1.0	F019	5	40	31.8	(33)
		1.2	F021	5	9	31.8	(33)
0.8		F918	5	9	31.8	(33)	
* 2	$\phi 6.35 \times L30$	1.2	F915	5	9.7	30	(32.2)
* 3	$\phi 6.35 \times L30$	1.2	F502	5	9.7	30	(25)
* 4	$\phi 4.6 \times L14$	0.8	F024	5	10	14	(15)
	$\phi 4.6 \times L16$	0.8	F025	5	10	16	(17)
	$\phi 5.2 \times L20$	0.8	F026	5	10	20	(21)
		1.0	F036	5	10	20	(21)

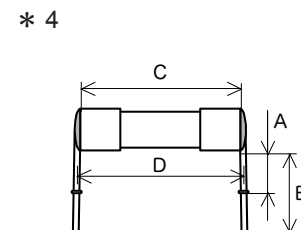
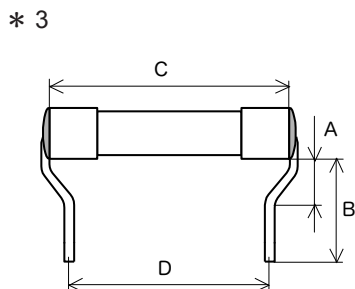
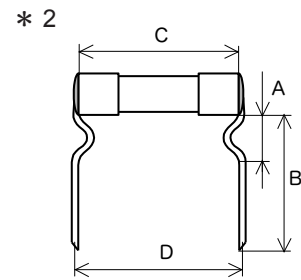
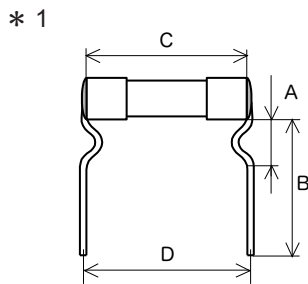

■ 25RT Type fuses (unit: mm, lead wire diameter: ϕ 0.8mm)

Forming No. F002

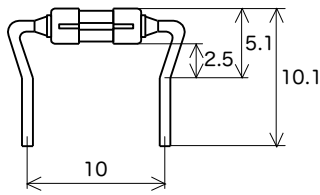

Forming No. F003

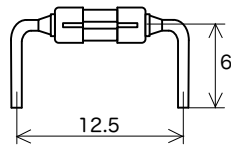

Forming No. F006

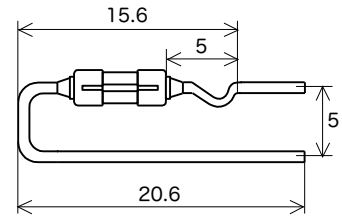

Forming No. F007

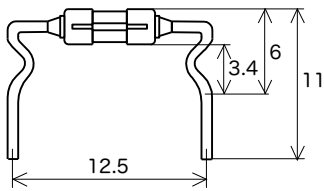

Forming No. F116



■ Lead wire forming

When forming by hand

○ Correct

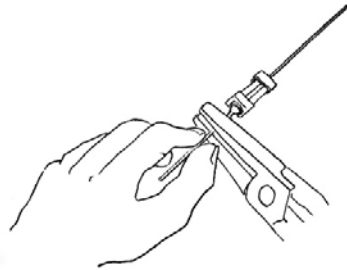

× Incorrect

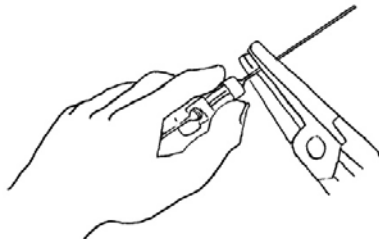

When forming with forming dies

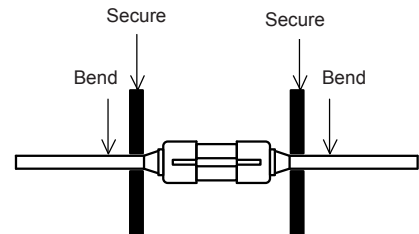

When forming lead wires, always secure the area between the fuse body and the part of the lead wire to be formed as shown in the figure above. Make sure not to put any stress on the area connecting the fuse body and the lead wire.